



DIXIE PRECAST, INC.

2950 ANGELETTE DRIVE, AUSTELL, GEORGIA 30106

(770) 944-1930 Fax (770) 944-9136

www.dixieprecast.com

DIXIE PRECAST

THIS PRINT REPRESENTS A PROPRIETARY PRODUCT AND IS OWNED BY DIXIE PRECAST INC. FOR THE USE OF ITS CUSTOMERS. IS NOT TO BE CONVEYED, NOR COPIED BY ANY OTHER PARTY WITHOUT THE EXPRESS WRITTEN APPROVAL OF THE OWNER.

THIS PRODUCT IS COVERED BY ONE OR MORE PATENTS

PATENTED

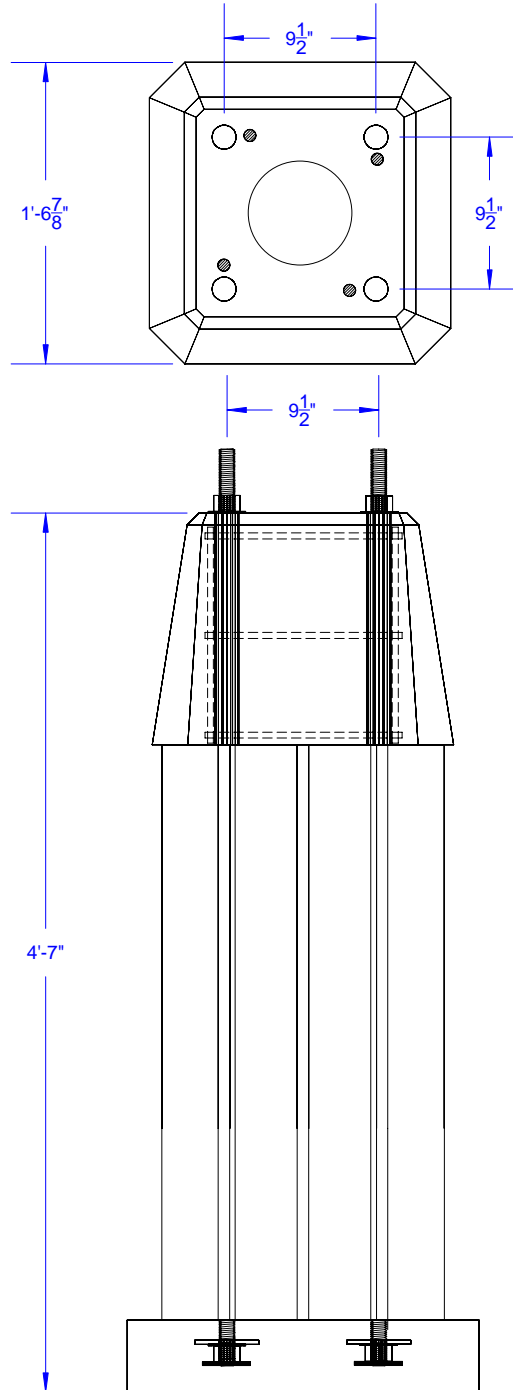

Note:

1. Galvanized steel anchor bolts, 1" diameter, on $9\frac{1}{2}" \times 9\frac{1}{2}"$ centers.
2. Net weight 1,000 lbs.
3. Foundation shipped fully assembled.

DPS-1A Precast Signal Foundation

Elevation View 4' - 6"